

Motor protective circuit breaker MS25

Main application field: control (start-up, protection and switch-off) of AC electric motors with powers up to 11 kW (380/400 V) or other consumers up to 25 A; it can also be used as the main switch according to EN 60204 or VDE 0113 standards.

Versions:

- MS25 - with overload and short circuit protection
- MST25 - with overload protection

Manual control:

- START, STOP, push-buttons
- Test of release function (TEST)
- Phase-failure sensitivity according to IEC/EN 60947-4-1
- Automatic switch-off with thermal or magnetic release
- Control with under-voltage release or shunt release
- Isolating distance between contacts: 4.5 mm per contact place
- Hard wire or fine wire connection
- Simple and fast mounting by snap fitting on 35 mm wide mounting rail in compliance with EN 60715; fixing with two screws is also possible
- Vertical or horizontal operation position

Technical data - General

Standards		IEC/EN 60947-2, IEC/EN 60947-4-1, IEC/EN 60947-5-1, IEC/EN 60204
Climatic class		constant damp heat acc. to IEC 60068-2-78 cyclic damp heat acc. to IEC 60068-2-30
Degree of protection		IP20, after terminals covering IP20
Ambient temperature	°C	-25 ... +60
Storage temperature	°C	-25 ... +70
Temperature range of thermal compensation for overload release	°C	-5 ... +40
Mechanical and electrical endurance		100,000
Shock resistance acc. to IEC 68-2-27	g	20
Vibration resistance acc. to IEC 68-2-6		5 g - f = 5 ... 150 Hz
Overvoltage category / pollution degree		III / 3
Rated insulation voltage U_i	V	690
Rated impulse withstand voltage U_{imp}	kV	6
Weight	kg	0.252

Technical data - Main circuit

Designation of connection terminals			1 - L1; 3 - L2; 5 - L3; 2 - T1; 4 - T2; 6 - T3
Terminal capacity	rigid	S (mm ²)	0.75 ... 6
	flexible		0.75 ... 4
Screw			with self-lifting clamp, protected against falling out
Screw head			PZ2
Tightening torque		Nm	1,8
Max. operational voltage	U_e	V	690
Setting range		A	0.1 - 0.16 (MS25); 0.16 - 0.25 (MS25); 0.25 - 0.4; 0.4 - 0.63; 0.63 - 1; 1 - 1.6; 1.6 - 2.5; 2.5 - 4; 4 - 6.3; 6.3 - 10; 10 - 16; 16 - 20; 20 - 25
No. of poles			3
Operating current of thermal overload release	I		$1.05 I_r < I \leq 1.20 I_r$
Sensitivity to phase failure			✓
Operating current of magnetic overload release	I		$11 I_n < I \leq 13 I_n \pm 20\%$
Power dissipation on pole at load with In	P	W	2 - 2.5
Utilization category	IEC/EN 60947-4-1		AC-3
	IEC/EN 60947-2		A
Trip class acc. to IEC/EN 60947-4-1			10A

MS25 motor protection switches, rated ultimate short-circuit breaking capacity Icu and max. back-up fuses if prospective short-circuit current Icp exceeds Icu:

Type	Operating current of short-circuit release (A)	Rated ultimate short-circuit breaking capacity Icu (kA)				Max. back-up fuse, if Icp > Icu (gL) (A)			
		230 V	400 V	500 V	690 V	230 V	400 V	500 V	690 V
MS 25 - 0,16	2	50	50	50	50	No back-up fuse required			
MS 25 - 0,25	3	50	50	50	50				
MS 25 - 0,4	5	50	50	50	50				
MS 25 - 0,63	8	50	50	50	50				
MS 25 - 1	12	50	50	50	50				
MS 25 - 1,6	20	50	50	50	50				
MS 25 - 2,5	33	50	50	3	2,5			25	20
MS 25 - 4	44	50	50	3	2,5			35	25
MS 25 - 6,3	75	50	50	3	2,5			50	35
MS 25 - 10	120	50	6	3	2,5		80	50	35
MS 25 - 16	160	6	4	2,5	2	80	80	63	35
MS 25 - 20	230	6	4	2,5	2	80	80	63	50
MS 25 - 25	270	6	4	2,5	2	80	80	63	50

Switch selection for motor protection

Single-phase		Standard motor power					Setting range
		3-phase					
220 V	230 V	220 V	380 V	440 V	500 V	660 V	A
230 V	240 V	230 V	400 V	440 V	500 V	690 V	
240 V	240 V	240 V	415 V	440 V	500 V	690 V	
kW							
			0,02			0,06	0,1 ... 0,16
			0,06	0,06	0,06	0,09	0,16 ... 0,25
		0,06	0,09	0,12	0,12	0,18	0,25 ... 0,4
		0,09	0,12	0,18	0,25	0,25	0,4 ... 0,63
0,06 ... 0,09	0,09 ... 0,12	0,18 ... 0,25	0,25	0,37	0,37 ... 0,55	0,37 ... 0,55	0,61 ... 1
0,12	0,18 ... 0,25	0,37 ... 0,55	0,37 ... 0,55	0,75 ... 1,1	0,75 ... 1,1	1,1	1 ... 1,6
0,18 ... 0,25	0,37	0,75 ... 1,1	0,75 ... 1,1	1,1	1,5	1,5	1,6 ... 2,5
0,37	0,55 ... 0,8	1,1 ... 1,5	1,5	1,5	1,5 ... 2,2	2,2 ... 3	2,5 ... 4
0,55 ... 0,75	1,1 ... 1,5	2,2 ... 2,5	2,2 ... 3	3	4	4	4 ... 6,3
1,1 ... 1,5	1,5 ... 2,5	3 ... 4	4 ... 5	4 ... 5,5	5,5 ... 7,5	5,5 ... 7,5	6,3 ... 10
2,2	3 ... 4	5 ... 7,5	5,5 ... 9	7,5 ... 9	11	11	10 ... 16
3	5,5	9	11	11 ... 12,5	15	15	16 ... 20
	5,5 ... 7,5	11 ... 12,5	12,5	15	18,5	18,5	20 ... 25

Tripping characteristic

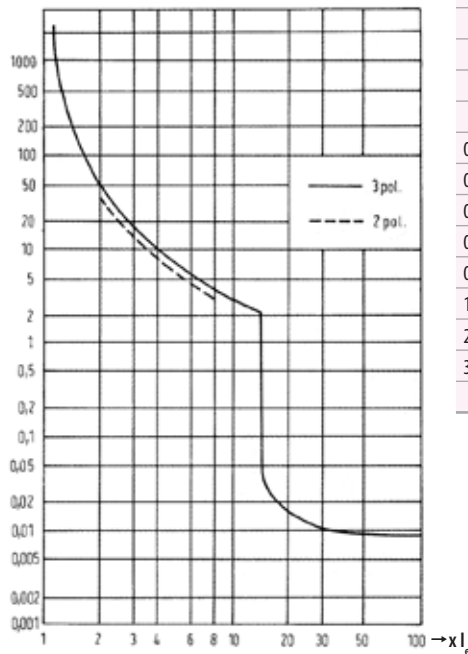

MST25 motor protection switches and max. back-up fuses for short-circuit protection:

Type	Max. back-up fuse Ue < 400 V gL (A)
MST 25 - 0,4	1
MST 25 - 0,63	2
MST 25 - 1	2
MST 25 - 1,6	4
MST 25 - 2,5	6
MST 25 - 4	16
MST 25 - 6,3	20
MST 25 - 10	25
MST 25 - 16	35
MST 25 - 20	50
MST 25 - 25	50

Accessories

Auxiliary switch for lateral mounting PS		
Rated insulation voltage U_i	V	500V
Thermal current I_{th}	A	6 A
Rated operational current at AC-15 230V/400V/500V I_e	A	3,5 A / 2 A / 1,5 A
Terminal capacity	mm ²	0,75 - 2,5 mm ²
Tightening torque	Nm	1

PS mounting

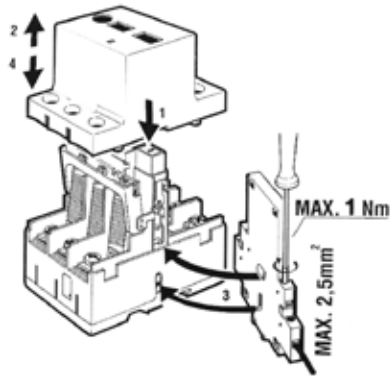

PS designation of contacts

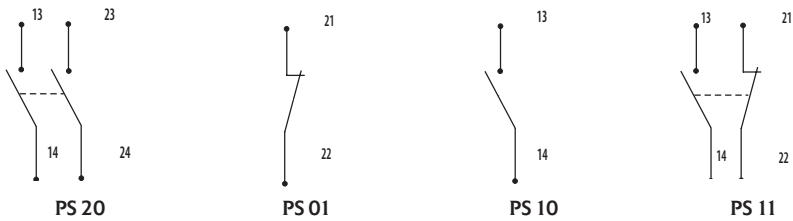

Under-voltage release U Shunt release A		
Control voltages U_c	V	24 V - 600
Rated frequency f	Hz	50 - 60

Mounting of UV and shunt release

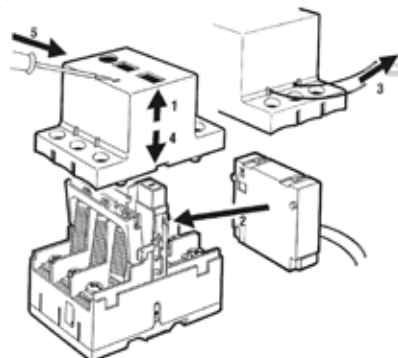

Connection diagram

1-p

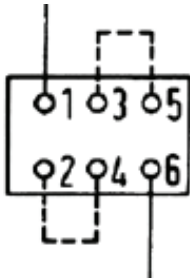

2-p

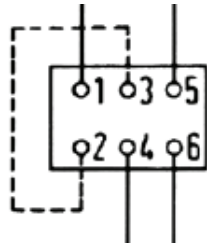

3-p

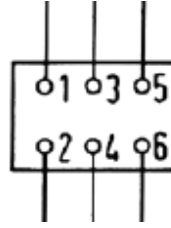

Dimensions

MS25, MST25

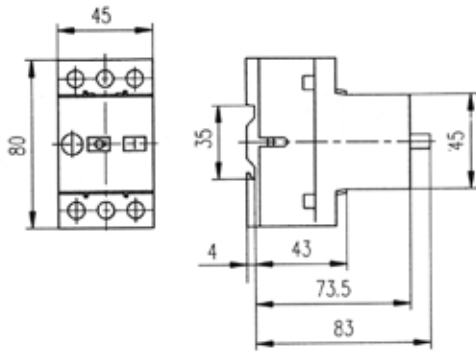

Auxiliary switch PS

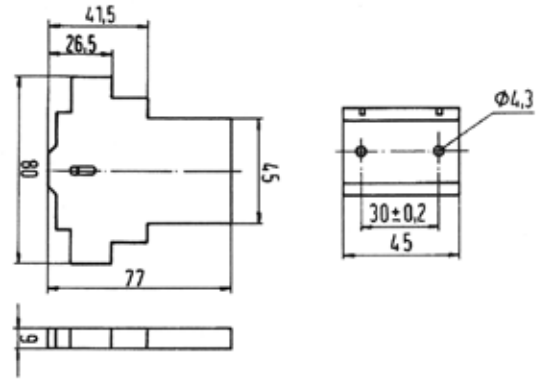

Insulated Enclosure O,
Front plate CP

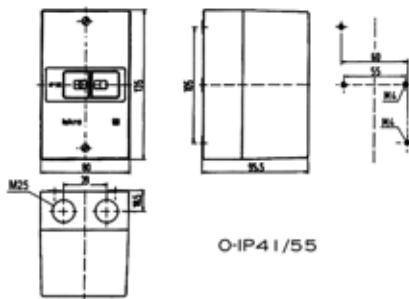

O-IP41/55

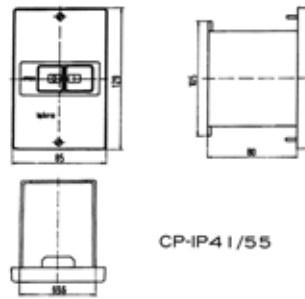

CP-IP41/55